

Start Here

Kodak ESP 3 All-in-One Printer

Print
Copy
Scan



Note: A USB 2.0 cable is required to connect your Kodak All-in-One printer to your Windows or Macintosh OS computer.

1

Unpacking the Printer

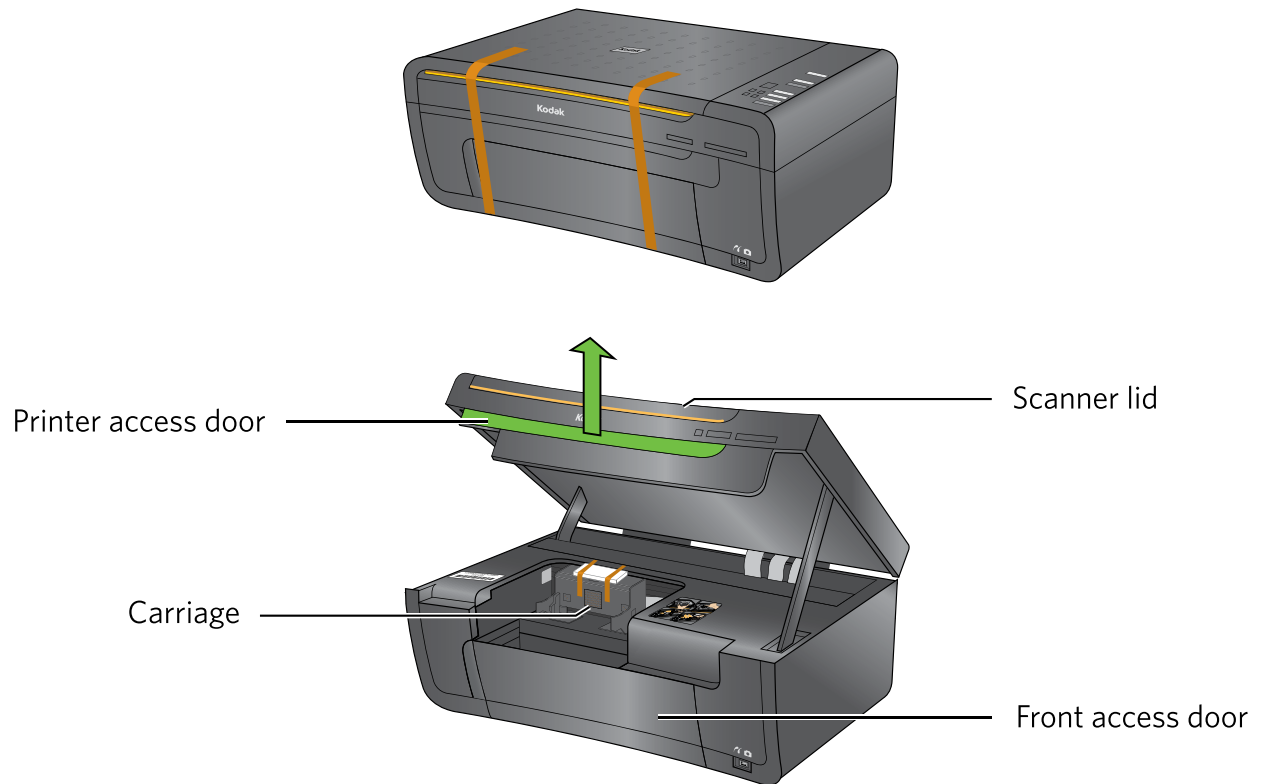

- a)** Lift the printer access door. Remove all orange shipping tape and the white styrofoam piece from the printer.

2



Printhead

3



Ink Cartridges

4



Power Cord
and Adapter

5



Sample Paper

6



Software CD &
User's Guide

2

Inserting the Printhead

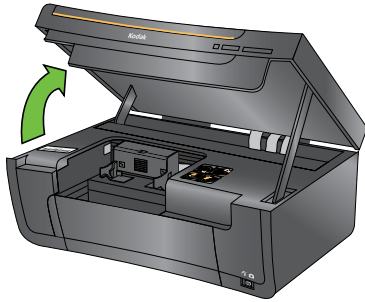

a) Lift the printer access door.

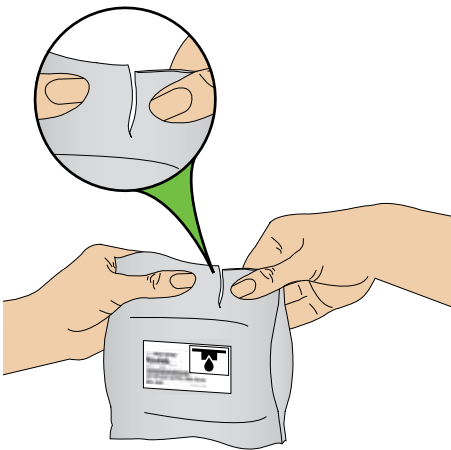

b) Remove the printhead from its bag.

⚠ Insert the printhead immediately upon opening sealed bag. The printhead is fragile, handle carefully.

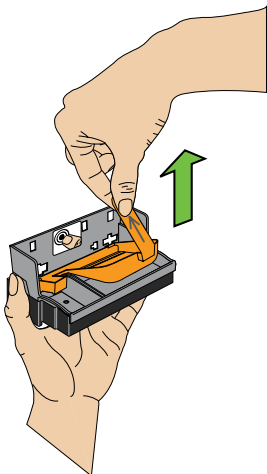

c) Pull on the orange tab to remove the protective retainer.

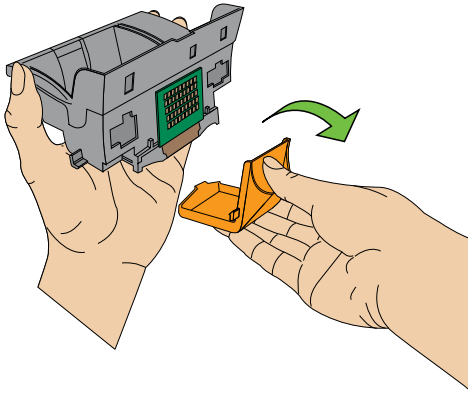

d) Carefully remove and discard the black plastic shield and the orange protective cap.

⚠ Do not touch the copper-colored contacts.

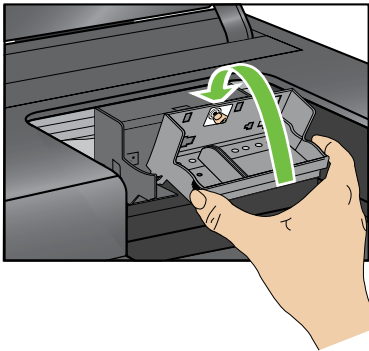

e) Place the printhead into the carriage. Insert at the angle shown.

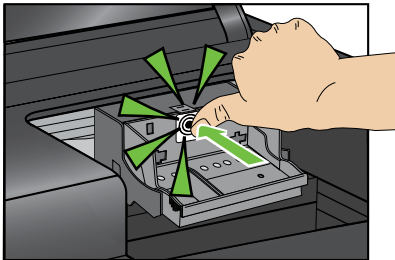

f) Push **firmly** against the target label of the printhead until you hear a **loud snap**.

3

Inserting the Ink Cartridges

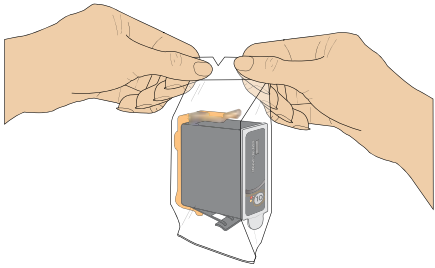

a) Remove the black ink cartridge from its bag.

⚠ Insert ink cartridges immediately upon opening sealed bag.

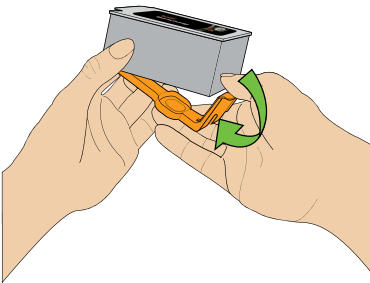

b) Carefully remove and discard the orange cap. Handle ink cartridges carefully to avoid ink transfer.

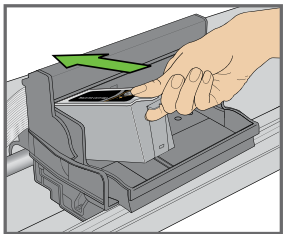

c) Insert the black ink cartridge into the printhead.

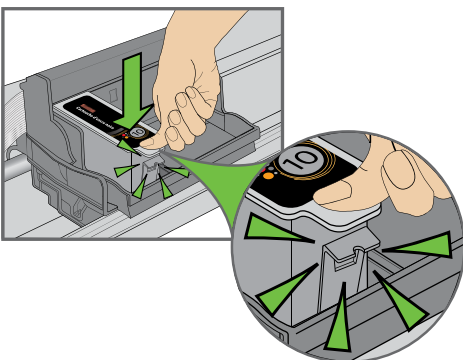

d) Press down on the ink cartridge until you hear it click into position.

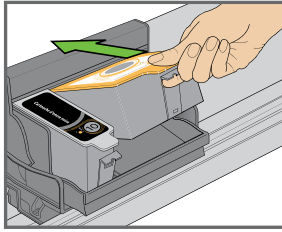

- e)** Open and uncap the color ink cartridge. Insert it into the printhead.

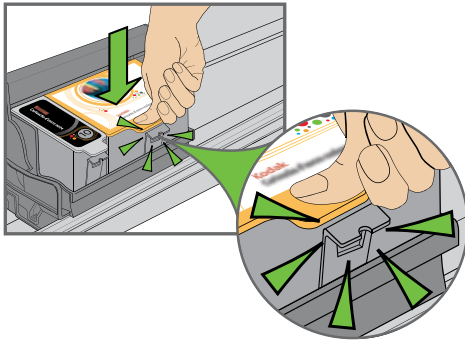

- f)** Press down firmly on the ink cartridge until you hear it click into position.

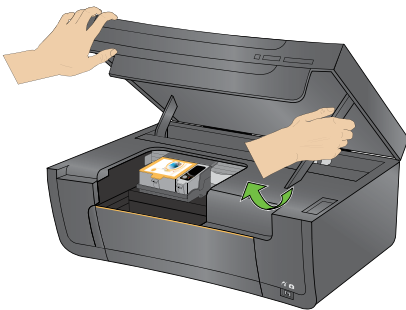

- g)** Close the printer access door.

4

Connecting Power and Calibrating

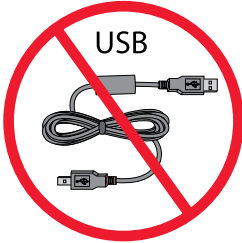

⚠ Do not connect the USB cable to the printer until instructed during software installation.

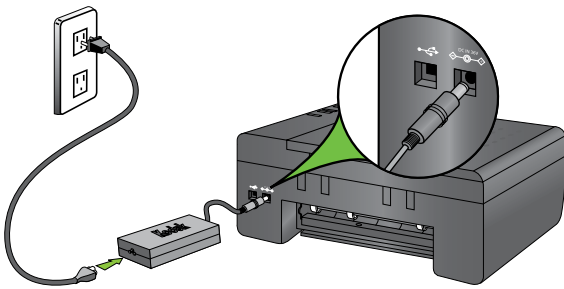

- a)** 1. Connect the power cord and adapter.
2. Connect the adapter to the printer.
3. Connect to the power source.

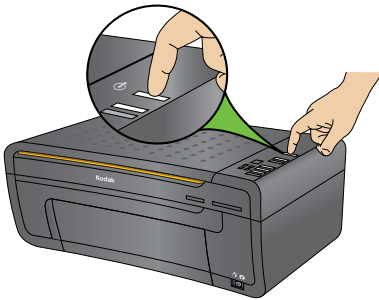

- b)** Press ON .

Wait for system maintenance to finish and a flashing "C" to be displayed in the quantity window.

A flashing "E" in the quantity window indicates the printhead is not installed correctly. Remove the ink cartridges and reinstall the printhead.

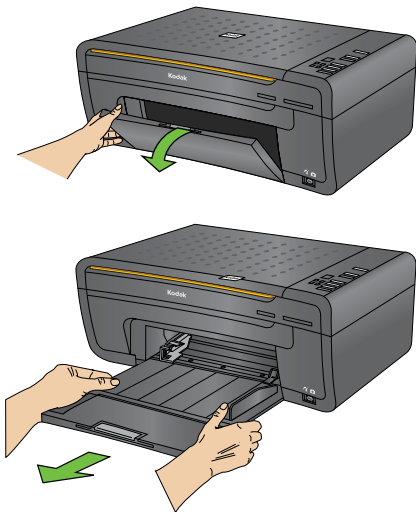

- c)** Lower the front access door and pull the paper tray all the way out.

4

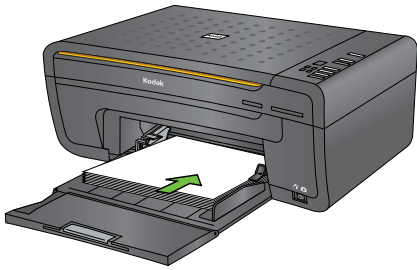

d) Insert a stack of plain paper into the paper tray.

 Leave the paper tray extended.

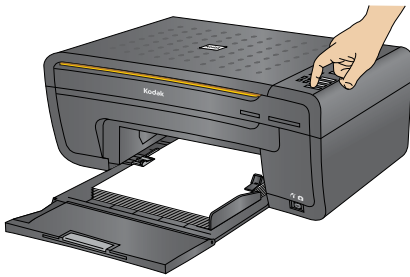

e) Press Copy/Resume.

The printer will automatically begin to calibrate.

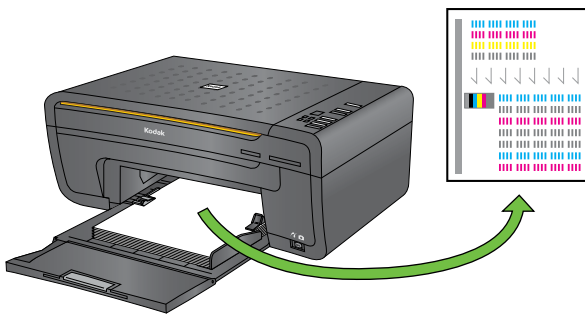

f) Calibration will take about two minutes and is complete when the sheet has printed.

5

Installing Windows Software

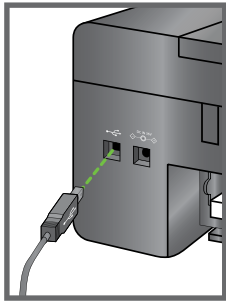
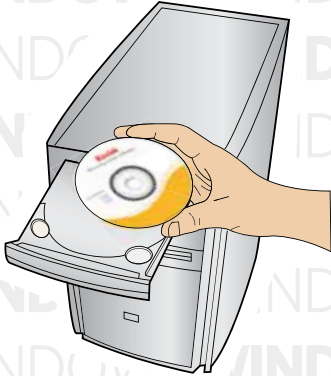

WINDOWS

 Do not connect the USB cable to the printer until instructed during software installation.

- a) Load the Kodak Inkjet Printer Software CD for Windows into the CD-ROM drive. Follow the on-screen prompts when the instructions appear.

If instructions do not appear, click **Start**, then **Run**. Select CD-ROM drive and type setup.exe, then press **ENTER**.

- b) Connect the USB cable to the printer when instructed. Continue to follow the on-screen prompts until installation is complete.



Kodak Home Center

You can use Kodak Home Center to browse, print, copy, scan, order supplies, and configure your AiO Printer from the computer.

5

Installing Macintosh Software

MACINTOSH MACINTOSH
MACINTOSH MACINTOSH
MACII INTOSH
MACI INTOSH
MACII INTOSH
MACI INTOSH
MACI INTOSH
MACI INTOSH
MACINTOSH MACINTOSH
MACINTOSH MACINTOSH
MACINTOSH MACINTOSH
MACINTOSH MACINTOSH
MACINTOSH MACINTOSH
MACINTOSH MACINTOSH
MACINTOSH MACINTOSH
MACINTOSH MACINTOSH
MACINTOSH MACINTOSH

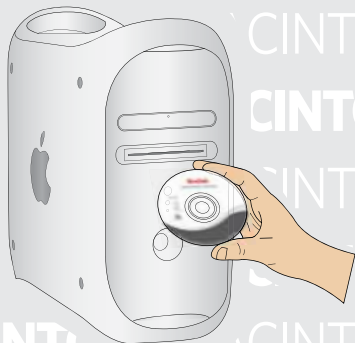
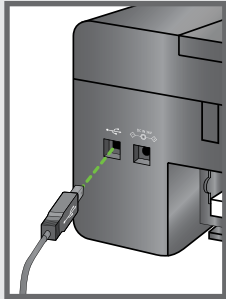

MACINTOSH

a) Connect the USB cable to the printer and your Macintosh computer.

b) Load the Kodak Inkjet Printer Software CD for Macintosh into the CD-ROM drive.

The Kodak AiO Printer software installer window should be displayed. If not, double-click the Kodak AiO Printer Software CD icon on the desktop. Follow the on-screen prompts until installation is complete.



Kodak Home Center

You can use Kodak Home Center to browse, print, copy, scan, order supplies, and configure your AiO Printer from the computer.

Warranty Information

Limited Warranty

Kodak warrants Kodak consumer electronic products and accessories ("Products"), excluding batteries, to be free from malfunctions and defects in both materials and workmanship for one year from the date of purchase. Retain the original dated sales receipt. Proof of the date of purchase will be required with any request for warranty repair.

Limited Warranty Coverage

Warranty service is only available from within the country where the Products were originally purchased. You may be required to send Products, at your expense, to the authorized service facility for the country where the Products were purchased. Kodak will repair or replace Products if they fail to function properly during the warranty period, subject to any conditions and/or limitations stated herein. Warranty service will include all labor as well as any necessary adjustments and/or replacement parts. If Kodak is unable to repair or replace a Product, Kodak will, at its option, refund the purchase price paid for the Product provided the Product has been returned to Kodak together with proof of the purchase price paid. Repair, replacement, or refund of the purchase price are the sole remedies under this warranty. If replacement parts are used in making repairs, those parts may be remanufactured, or may contain remanufactured materials. If it is necessary to replace the entire Product, it may be replaced with a remanufactured Product. Remanufactured Products, parts and materials are warranted for the remaining warranty term of the original Product, or 90 days after the date of repair or replacement, whichever is longer.

Limitations

This warranty does not cover circumstances beyond Kodak's control. This warranty does not apply when failure is due to shipping damage, accident, alteration, modification, unauthorized service, misuse, abuse, use with incompatible accessories or attachments (such as third party ink or ink tanks), failure to follow Kodak's operation, maintenance or repacking instructions, failure to use items supplied by Kodak (such as adapters and cables), or claims made after the duration of this warranty. KODAK MAKES NO OTHER EXPRESS OR IMPLIED WARRANTY FOR THIS PRODUCT, AND DISCLAIMS THE IMPLIED WARRANTIES OF MERCHANTABILITY AND FITNESS FOR A PARTICULAR PURPOSE. In the event that the exclusion of any implied warranty is ineffective under the law, the duration of the implied warranty will be one year from the purchase date or such longer period as required by law. The option of repair, replacement, or refund is Kodak's only obligation. Kodak will not be responsible for any special, consequential or incidental damages resulting from the sale, purchase, or use of this product regardless of the cause. Liability for any special, consequential or incidental damages (including but not limited to loss of revenue or profit, downtime costs, loss of the use of the equipment, cost of substitute equipment, facilities or services, or claims of your customers for such damages resulting from the purchase, use or failure of the Product), regardless of cause, or for breach of any written or implied warranty, is expressly disclaimed.

Your Rights

Some states or jurisdictions do not allow exclusion or limitation of incidental or consequential damages, so the above limitation or exclusion may not apply to you. Some states or jurisdictions do not allow limitations on how long an implied warranty lasts, so the above limitation may not apply to you. This warranty gives you specific rights, and you may have other rights which vary from state to state or by jurisdiction. Your statutory rights are not affected.

Outside the United States and Canada

In countries other than the United States and Canada, the terms and conditions of this warranty may be different. Unless a specific Kodak warranty is communicated to the purchaser in writing by a Kodak company, no warranty or liability exists beyond any minimum requirements imposed by law, even though defect, damage, or loss may be by negligence or other act.

Safety Information

- Read and follow these instructions before using KODAK products.
- Always follow basic safety procedures.
- Follow all warnings and instructions marked on the equipment.

WARNING STATEMENTS

- Do not expose this product to liquid, moisture, or extreme temperatures. KODAK AC adapters are intended for indoor use only. The use of controls, adjustments, or procedures other than those specified herein may result in exposure to shock and/or electrical or mechanical hazards.
- Keep ink cartridges out of reach of children. Ink may be harmful if swallowed.
- Do not place your AiO Printer on an unstable cart, stand, bracket, or table. Injury to persons and damage to the equipment may occur.
- The use of an accessory attachment that is not recommended by Kodak, such as an AC adapter, may cause fire, electric shock, or injury.
- Pushing objects through the equipment openings can result in an electric shock or risk of fire.

CAUTIONARY STATEMENTS

- Adjust only those controls covered in the operating instructions.
- Do not disassemble this product; there are no user-serviceable parts inside. Refer servicing to qualified service personnel.
- The AC adapter power supply is equipped with 3-wire grounding type plugs. If you cannot insert the plug into the power outlet, contact an electrician to check or replace the power outlet.
- Do not plug the AC adapter into a household extension cord.
- If the power cord or plug is frayed or damaged, the equipment gets wet, or the equipment does not operate normally when the operating instructions are followed, unplug your AiO Printer from the power outlet and contact Kodak qualified service personnel for further instructions.
- For added protection from damage during a lightning storm, or any time when your AiO Printer and its associated AC adapter will be left unused for long periods of time, unplug the AC adapter from the power outlet and any attached fax line from the printer.
- To prevent your AiO printer from overheating, do not place it near a heat register or install it in a cabinet without proper ventilation.
- Do not use your AiO Printer near water or spill liquid on it.
- Unplug the equipment from the wall outlet before cleaning.
- Dropping your AiO Printer may damage the housing and result in extensive damage that will require repair by a qualified technician to restore normal operation.
- Excessive dust levels may damage internal parts.

For more information, go to www.kodak.com/go/MSDS



Registration has its rewards— including a terrific offer.

Register your KODAK All-in-One Printer and get great support, expert tips, free software downloads—**plus a phenomenal deal on inkjet supplies to get you started.** Simply register right away when prompted during software installation or on the web at www.kodak.com/go/register. Registration takes a minute—but the rewards are lasting.

Inkjet supplies offer valid for U.S. residents only.

blank

blank

THANK YOU!

for purchasing this Kodak All-in-One printer. We have made every effort to provide you with the highest possible quality product. Should you need help with your printer or should your printer require service,

PLEASE DO NOT RETURN IT TO THE STORE.



If you need help, contact Kodak. For questions or assistance on installation, parts or operation, please contact Kodak Technical Assistance at **1-800-421-6699**.

Kodak provides several resources to help you troubleshoot and solve problems with your Kodak printer.



First, attempt to power cycle the printer by unplugging the printer. Wait 5 seconds, and then plug the power cord back into the printer.



You should also confirm that you are using a 2.0 USB cable. 2.0 USB cables can be purchased online at www.kodak.com/go/aio or at your local retailer.



Make sure that you have the most up-to-date software and Help files from the Web. Visit www.kodak.com/go/support to download the latest files.



Further, you can access topics for troubleshooting through Home Center by clicking the question mark (?) button at the top right corner of the Menu bar. In the help panel, select **Troubleshoot**.

The **User Guide** is installed with your Kodak Inkjet Printer Software and is located:

Windows: Start ▶ All Programs ▶ Kodak ▶ User Guide
Macintosh: Library ▶ Documentation ▶ Kodak AiO Printers



You can also get support from the Internet. Visit www.kodak.com/go/support for information on getting support for your Kodak printer.

Kodak

Eastman Kodak Company
Rochester, NY 14650 U.S.A.
© Eastman Kodak Company, 2008
MC/MR/TM: Kodak, EasyShare.

Printed in the U.S.A.
Windows® is a registered trademark of Microsoft Corporation
Macintosh® is a registered trademark of Apple Computer, Inc.



1K6184



A