



KODAK Film Container Recycling Program

Instructions for Labs that Process More Than 250 Rolls Per Day

What Is It?

The KODAK Film Container Recycling Program is designed to help photofinishers recycle their plastic and metal waste from 35 mm film processing which includes canisters, lids, spools, and cartridges. Photographic processing facilities reduce their overall process waste, and waste is diverted from landfills. Plastic from spools is made into products like sheet lifters. Steel from film cartridges is sent to steel mills to be made into wire. After culling and cleaning, the film cans and lids are ground up and re-extruded. The pellets are then sold back to Kodak to be used all over again in the manufacture of film container bottoms.

To participate in the program, follow the directions below for returning recyclables to Plastic Innovations.

What Do I Do?

If You Process More Than 250 Rolls Per Day:

<p>Order the collection and shipping supplies* through U.S. Customer Service at 1-800-847-8755:</p>
<ul style="list-style-type: none"> • Recycling collection gaylord/cover, CAT No. 844 9902 <ul style="list-style-type: none"> – Each order contains 10 gaylords and 10 lids – Each octagonal-shaped gaylord box holds waste from approximately 16,000 rolls of film or 400 pounds of plastic <p>* If you do not use Kodak paper and chemistry, there is a \$75 fee for each order of 10 gaylords and 10 lids. The \$75 fee is waived for photographic processing labs using 100% Kodak paper and chemistry.</p>
<p>Collect the following items and sort them as follows†:</p>
<ul style="list-style-type: none"> • Plastic 35 mm film cans/lids • 35 mm magazines/spools, 120/220 spools • Kodak plastic core plugs, 110 & 126 cartridges, Disc, Super-8, Photo CD jewel boxes (plastic protective case)
<p>Do NOT send the following items:</p>
<ul style="list-style-type: none"> • Paper cores (see KODAK Publication No. PF3-561) • Chemical containers • Waste paper (film boxes, envelopes, etc.) • Backing paper (110, 126, and 120/220 spools)
<p>To ship recyclables:</p>
<ul style="list-style-type: none"> • Use a carrier of your choice. You are responsible for paying the freight bill. Be sure to fill the truck to get the lowest shipping prices per pallet. • Make copies of the attached shipping label, fill in your name with the destination and apply a label to each gaylord with masking tape. Carriers will not ship unless each gaylord is labeled.

† You can recycle one-time-use cameras but you *will forfeit* the refund. You should recycle one-time-use cameras through the One-Time-Use Camera Recycling Program. For more information, see KODAK Publication No. A7-340.

<p>To ship via your carrier:</p> <ul style="list-style-type: none"> • Make arrangements with the <i>carrier of your choice</i> on a "PREPAID" basis <ul style="list-style-type: none"> – Do NOT ship freight "COLLECT" or "THIRD PARTY BILLING" • Use <i>your</i> bill of lading or one provided by your carrier <ul style="list-style-type: none"> – Do NOT use the Kodak Bill of Lading • Mark the shipping papers "PREPAID" • You MUST tell your carrier to make an appointment at the recycler's facility <i>in writing</i> on the bill of lading. Call the appropriate Plastic Innovations recycling location for an appointment. <ul style="list-style-type: none"> – If you ship to Plastic Innovations in California (see "Where to Ship," below), write "Call for an appointment: 1-562-945-7577" or for more information, call 1-800-777-7644 – If you ship to Plastic Innovations in Indiana (see "Where to Ship," below), write "Call for an appointment: 1-317-362-9675" • Pay the carrier's freight bill, which will be submitted directly to you <ul style="list-style-type: none"> – Kodak will NOT pay the freight bill from your carrier
<p>Where to ship:</p> <ul style="list-style-type: none"> • If you are located in AK, AZ, CA, CO, HI, ID, MT, NM, NV, OR, UT, WA, ship to: Plastic Innovations, Inc. 7440 Scout Avenue Bell Gardens, California 90201 1-562-945-7577 (call this number for shipping arrangements/appointments only) or for more information, call 1-800-777-7644 • If you are located in any other state, ship to Plastic Innovations, Inc. 906 Lane Ave. Crawfordsville, IN 47933 317-362-9675 (call this number for shipping arrangements/appointments only)

Questions?

For more information, call Kodak Information Center at 1-800-242-2424 or visit www.kodak.com/go/kes.

KODAK Film Container Recycling Program

Q&As

- Q. *Who can participate in the program?*
- A. Anyone who processes photographic film.
- Q. *Why did Kodak set up the Film Container Recycling Program?*
- A. The program was set up so that photographic processing facilities, large and small, would have access to recycling facilities for certain types of photographic wastes that are not commonly recycled in local community programs.
- Q. *Why should I participate in the program?*
- A. Consumers are becoming more and more aware of solid waste concerns. Participation in the program allows photographic processing facilities to advertise and promote their environmental consciousness to their customers. It can also save processing facilities money, in certain situations.
- Q. *What items should I recycle using the program?*
- A. You can recycle 35 mm film cans/lids, 35 mm magazines/spools, 120/220 spools, 110/126 cartridges, disc, Super 8, one-time use cameras, and Kodak plastic core plugs from color photographic paper. The tape on 35 mm film spool does not need to be removed. You cannot recycle paper cores, non-Kodak one-time use cameras, chemical containers, backing paper (from 110, 126, 120, 220 products) and waste paper (film boxes, envelopes, etc.)
- Q. *Why can't I send paper cores with my other recyclables to the same recycler?*
- A. The program recyclers cannot recycle paper. However, Kodak offers the Sonoco Fiber Core Recycling Program for recycling these cores. For more information on this program, contact Kodak Information Center at 1-800-242-2424.
- Q. *Why is the refund forfeited if I put Kodak one-time use cameras in the box?*
- A. Kodak has set up a special process to handle only cameras and reimbursement to customers at our facility in Rochester, NY. It is impossible for the Film Container Recycling Program recyclers to keep track of cameras that are included with all the other recyclables that come to their facilities for proper crediting.
- Q. *Why can't I put chemical bottles in the recycling bin?*
- A. The recyclers for the Film Container Recycling Program cannot handle chemical container bottles in their recycling processes. To investigate local recycling options, contact your local municipal recycling coordinator or look for recyclers in your Yellow Pages. See KODAK Publication No. CIS-148, *Recycling KODAK Photochemical Containers*.
- Q. *Why do I have to sort my recyclables?*
- A. The sorting we ask you to do is only the first step in recycling photographic components. The recyclers perform three to four additional sorting and cleaning steps in order to prepare the materials for their next use. By sorting your recyclables, you are doing your part to make the program work.
- Q. *Why do I need to use shipping boxes supplied by Kodak?*
- A. Other containers that you receive your products in are not strong enough to hold the recyclables. Broken boxes create handling problems for the person transporting your recyclables *and* the recycler.
- Q. *I don't have a lot of indoor storage space. Can I store the recycling boxes outside?*
- A. Recycling boxes must be stored in a **dry** location. Wet recycling boxes will break during transport and create problems for the person transporting your recyclables *and* the recycler.
- Q. *Can I get a trailer placed ("spotted") at my facility for storing recyclables?*
- A. Yes, but you have to pay for the trailer. You will need to contact a local carrier to investigate "spotting" a trailer at your facility.
- Q. *Isn't there a recycler closer to my area who I can ship to?*
- A. Kodak has found that there were very few processing facilities that could find local recycling opportunities for the items managed in the Film Container Recycling Program. Since recyclers need certain volumes of material to break even financially, we could only have a few recyclers in the program.
- Q. *Are the materials I send into the Film Container Recycling Program really reused?*
- A. Yes, the materials are sold and reused for a number of applications. For example, Kodak has signed a purchasing agreement to buy back the recycled polyethylene for reuse in film cans. Other uses include: office supplies (page lifters and notebooks).
- Q. *Who do I call for more information?*
- A. Contact the Kodak Information Center (KIC) at 1-800-242-2424. Please refer to the KODAK Film Container Recycling Program.

FROM:

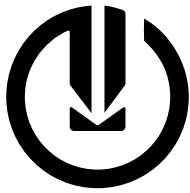

Kodak
Environmental Information

TO:

Assemble Corrugated Cap and Octagon Container as shown:

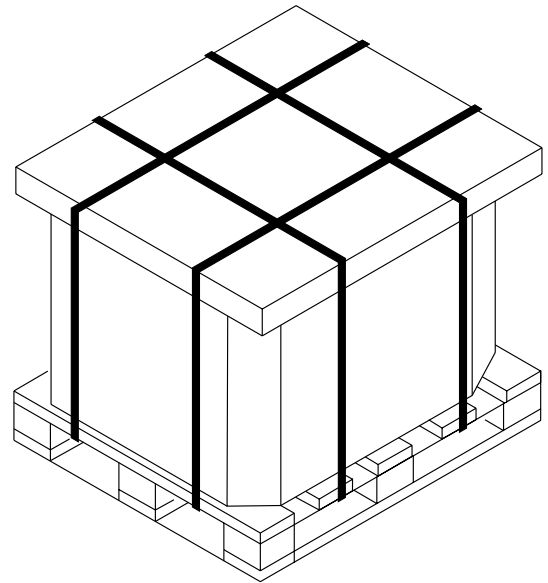
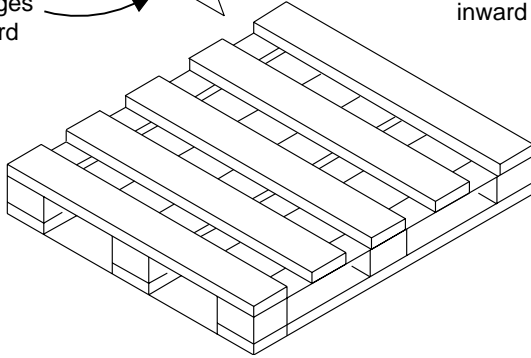
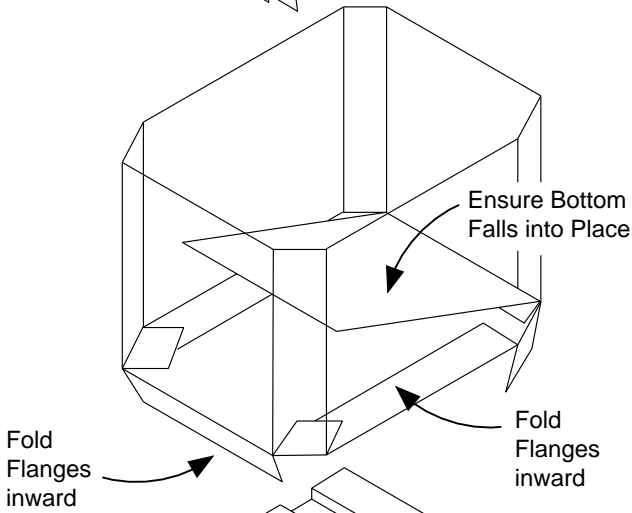
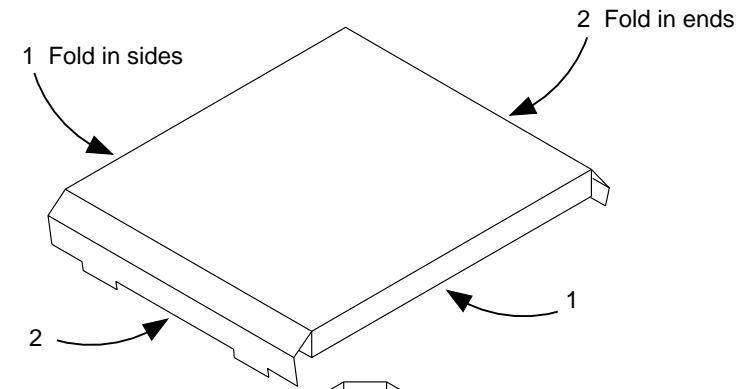

Octagon Container Should be Banded or Stretch Wrapped to the Pallet for Return Shipment.

KODAK Film Container Recycling Program

Consumer Imaging
EASTMAN KODAK COMPANY • ROCHESTER, NY 14650

