

Dimensional Change Characteristics for Printed Circuit Board Films

—High Complexity PCB Starts With the Right Phototools—

March 2003 • TI-2530

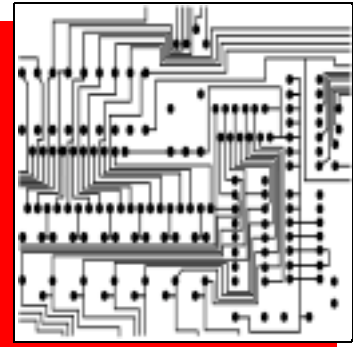

INTRODUCTION

Kodak films for PCB phototooling have the following component layers:

- a plastic base
- a photosensitive emulsion layer (silver halide)
- and a backing layer

The 3 layers interact to cause dimensional change.

Kodak films for phototooling are coated on ESTAR Thick Base. This plastic base is polyester material, made of polyethylene terephthalate (PET).

Thickness of film for phototooling use is 0.18 mm (0.007 inch, or 7 mil). Thickness of the emulsion and backing layers are usually about 0.005 mm (0.0002 inch, or 0.2 mil).

The emulsion layer is composed of gelatin and polymer that act as a binder for silver halide and other chemicals. The backing layer is composed of gelatin and other chemicals, including matte particles.

Some Kodak films (ALI7, ABX7, ARD7) lack the backing layer. Elimination of the backing layer reduces dimensional size change with change in relative humidity.

The four factors that cause size change of photographic films are:

- Relative humidity
- Temperature
- Processing
- Aging

Relative Humidity

The polyester base itself absorbs and desorbs moisture from the ambient environment. As the plastic absorbs moisture, it expands. As the plastic releases moisture, it contracts. The process is slow. It takes one hour per 0.0254 mm (0.001 inch, or 1 mil) of thickness to reach 99% equilibrium with the ambient environment. The humidity coefficient of expansion for polyester base is 0.0008%/ % RH. The humidity coefficient is a constant, regardless of the thickness of the polyester base.

Gelatin in the emulsion and backing layers also absorb and desorb moisture. Both layers are tightly bonded to the plastic base. As the gelatin layers expand and contract, they exert tremendous forces on the tightly bonded plastic base, causing expansion and contraction. Films with high gelatin concentration (thick layers) will exert greater forces than films with lower gelatin concentration (thin layers). The gelatin layers coated on polyester base therefore will increase the humidity coefficient from 0.0008%/ % RH to a higher value, depending on the concentration of gelatin. The process is very fast. Gelatin absorbs and desorbs moisture very quickly. It takes less than 2 or 3 minutes for gelatin layers to reach 99% equilibrium with the ambient environment.

The process of absorption and desorption by both the base and the gelatin layers is considered to be completely reversible. Effects of hysteresis are negligible with today's films.

Humidity Coefficient is expressed as % Size Change per % Change in Relative Humidity (% / % RH). Note that processed film will always have a lower humidity coefficient than unprocessed film.

Table I: Humidity Coefficient for KODAK ULTRALINE Photoplotter Film ALI7 Film

Unprocessed Film	Processed Film
0.0011% / % RH	0.0009% / % RH

Temperature

Photographic film expands as the surrounding air temperature goes up, and contracts as the temperature goes down. The temperature coefficient of expansion for polyester base is 0.0018%/ °C (0.001%/ °F). The temperature coefficient is a constant, regardless of the thickness of the polyester base.

The equilibration rate is fast. The entire film structure will equilibrate to ambient air temperature in less than 2 to 3 minutes.



Expansion and contraction with temperature is a reversible process. However, if film is heated to 60°C (140°F), a permanent change will occur. The polyester can shrink or expand to relieve minor stresses remaining from manufacture. The magnitude of these changes is $\pm 0.01\%$, not easily controlled, and they are permanent.

Temperature Coefficient is expressed as % Size Change per Degree Change in Temperature (% / °T). Note that all polyester based films have the same temperature coefficient and it is the same for both processed and unprocessed film, and is independent of thickness.

Table II: Temperature Coefficient for All Films

Unprocessed Film	Processed Film
0.0018 % / °C (0.001% / °F)	0.0018 % / °C (0.001% / °F)

Processing

Film processing will reduce the humidity coefficient of the unprocessed film (see Table I). Film processing changes the gelatin structure by removing some of the chemical components of the raw film. The unexposed silver halide is removed from the image-forming layer by the fixer solution. The antihalation backing layer also contains chemicals that are removed during processing. Removal of these chemicals lowers the strength of the gelatin and thus reduces the forces on the base. There is an additional processing dimensional change (PDC) that is associated with the drying temperature. Films that are over-dried will be over-sized. Films that are under-dried will be under-sized. The magnitude of this PDC with current 0.18 mm thick films is within $\pm 0.02\%$.

Coefficients of humidity expansion are an indicator but cannot be used to predict the exact extent to which films change size as a result of processing. With preconditioned film that has been dried at the optimum dryer temperature, the PDC can be too small to measure.

There is a dryer temperature that will produce a zero PDC. This zero-point drying temperature will vary depending on the type of film. For a given film, the ideal drying temperature is highly dependent on the ambient relative humidity, and on the relative humidity of the air within the dryer of the machine processor. Therefore the ideal dryer temperature must be empirically determined under the actual conditions of use. Use the following chart to find an approximate drying temperature range and then adjust the drying temperature up or down depending on the size changes observed.

Table III: Guide to Dryer Temperature for Minimum Processing Size Change

Film Group	Ambient Relative Humidity	Dryer Temperature
ALI7, ABX7, ARD7	40%	27 - 32°C (80 - 90°F)
RED7, AGX7, LPF7	40%	41 - 46°C (105 - 115°F)
ALI7, ABX7, ARD7	50%	32 - 38°C (90 - 100°F)
RED7, AGX7, LPF7	50%	43 - 49°C (110 - 120°F)
ALI7, ABX7, ARD7	60%	35 - 41°C (95 - 105°F)
RED7, AGX7, LPF7	60%	46 - 54°C (115 - 130°F)

Aging

Size changes due to aging of ESTAR Thick Base (0.18 mm) are relatively insignificant. Polyester base can show a $\pm 0.01\%$ change over a period of 5 to 10 years. Changes are dependent on the humidity and temperature of storage. Storage at high humidity will probably result in a slight swell. Storage at high temperature will result in a slight shrinkage (as much as 0.02%).

DIMENSIONAL STABILITY

Kodak Films for PCB Phototools

Films can be grouped into 2 classes: films that do not have a gelatin backing layer and films that do have a gelatin backing layer.

- Films With No Gelatin Backing
 - KODAK ULTRALINE Photoplotter Film ALI7
 - KODAK ACCUMAX Photoplotter Film ABX7
 - KODAK ACCUMAX Photoplotter Film ARD7
- Films With Gelatin Backing
 - KODAK ACCUMAX Photoplotter Film AGX7
 - KODAK PRECISION LINE Film LPF7
 - KODAK ACCUMAX Photoplotter Film RED7

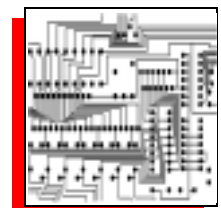

Table IV: Film Listing of Humidity and Temperature Coefficients

Film	Humidity Coefficient % / % RH Unprocessed	Humidity Coefficient % / % RH Processed	Temperature Coefficient % / % °T Unprocessed or Processed
ALI7	0.0011	0.0009	0.0018% / °C (0.001% / °F)
ABX7	0.0011	0.0009	0.0018% / °C (0.001% / °F)
ARD7	0.0011	0.0009	0.0018% / °C (0.001% / °F)
AGX7	0.0013	0.0012	0.0018% / °C (0.001% / °F)
LPF7	0.0016	0.0015	0.0018% / °C (0.001% / °F)
RED7	0.0015	0.0014	0.0018% / °C (0.001% / °F)

ISO 6221:1996(E)

ISO Reference:

Both the Humidity Coefficients and the Temperature Coefficients are measured in accordance with ISO 6221:1996(E), “Photography—Films and Papers—Determination of Dimensional Change.”

Humidity:

Coefficients are determined between 15 to 50% RH, at a temperature of 21.1°C (70°F). The procedure conforms to the range of relative humidity specified in ISO 6221:1996(E). This procedure is relatively severe, since size change is not linear with humidity, but is steepest at low humidity extremes. This coefficient will be lower for a given film if it is determined over 30 to 60% humidity range and still lower at a higher range such as 50 to 80% humidity range. An example of the unprocessed humidity coefficient of a typical film on 7-mil (0.18 mm) ESTAR Base tested over these three ranges is shown the table below.

Table V: Humidity Coefficient of Linear Expansion Example of Humidity Coefficient Measured at Low, Medium, and High Humidity Unprocessed (% per % RH)		
Low Range 15 to 50%	Medium Range 30 to 60%	High Range 50 to 80%
0.0014	0.0012	0.0010

When comparing humidity coefficients of various films, it is important to know the humidity range that was used to determine them.

Temperature

Coefficients are determined between 21.1°C and 48.9°C (70°F and 120°F) at 20% RH. The procedure conforms to the range of temperatures specified in ISO 6221:1996(E). Thermal coefficient is very similar for all ESTAR Base films, regardless of support thickness, or whether the film is unprocessed or processed (see Table II).

Effect of Silver Content—Amount of Exposure, Negative vs. Positive

The amount of developed silver can influence the size change of film. Negatives having a high ratio of black area vs. clear area will have very slightly less size change compared to positives that have a low ratio of black area vs. clear area. High silver content does affect the strength or modulus of the gel. High silver content makes for a stronger gel. The magnitude of this effect is very small—about ±10% of the total effect. If there is a 10-micron average change, there could be 1-micron variation, depending on the silver content. Within this magnitude of variation, minor differences can be measured with some sophisticated methods.

Equilibration Rate

Humidity:

Time required to reach equilibrium with relative humidity depends on the thickness of the film. It takes 1 hour per 0.001 inch (0.0254 mm) of film thickness to reach nearly complete equilibrium to relative humidity. Table VI shows the difference between 0.18 mm and 0.10 mm films.

Table VI: Humidity Equilibration Rate for 0.18 mm and 0.10 mm Thickness Films

Percent Equilibrium To Relative Humidity	Time Required Film Thickness 0.18 mm (0.007-inch)	Time Required Film Thickness 0.10 mm (0.004-inch)
50%	1 hour	0.4 hour
75%	2 hours	1 hour
90%	4 hours	2 hours
99%	7 hours	4 hours

Note: To fully equilibrate in the time shown, films must be completely separated, with both sides of the film exposed to the ambient humidity. This is most easily accomplished by placing individual sheets of film on separate shelves in a conditioning cabinet.

Temperature:

Film equilibrates to ambient temperature within 1 to 3 minutes.

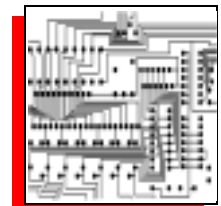

Non-Uniaxialism—Difference in X and Y Dimensional Change

A perfectly uniaxial film base will have identical properties in X, Y, and diagonal directions within the plane of the sheet of film. ESTAR Base is intentionally stretched during manufacture in both length and width directions. The degree and rate of stretch during extrusion is carefully controlled so that the finished support displays as high a degree of uniaxialism as possible. The manufacturing process of polyester base is not absolutely perfect. These are not random variations, but are measurable and controlled levels of non-uniaxialism, as it is called. During manufacture, the polyester is stretched and molecularly locked together in a definite plan or pattern within the roll of extruded polyester. With very precise and accurate measurement, large sheets of film can show slightly different dimensions of size change in X and Y direction.

The dimensional properties of ESTAR Base may vary slightly in different directions within a sheet; the differences that may exist, however, are not always equal in both the length and width directions. Differences in size change between length and width should be within ± 10 percent of each other. If there is a 10-micron average change, there could be 1-micron variation in X and Y dimensions.

Hysteresis

Hysteresis refers to a non-reversible humidity size change that is “humidity-directional” in origin. This “humidity-directional” effect means that a film will not completely return to original size, and depends on whether the film is coming from a low humidity, or is coming from a high humidity. The following is an example:

Two Films, Film A and Film B start with the same size at 50% RH.

Film A is taken to a very low humidity, and then returned to equilibrium at 50%.

Film A will show a very slight increase in size compared to the original size.

Film B is taken to a high humidity, and then returned to equilibrium at 50%.

Film B will show a very slight decrease in size compared to the original size.

These phenomena have been well documented in the technical literature. With older generation films, constructed with thick gels layers, and low modulus base, hysteresis was a noted factor and important to consider. Hysteresis effects are greatly reduced with newer films that are made with thin, low gel layers, and with high polymer content. With new films today, the effect is of no practical consequence. The magnitude of this effect is less than 10% of whatever size change can occur. If the size of film were to show a 10-micron change in dimension, the directional or hysteresis effects might cause a 10% variation of this (or ± 1 micron). With newer films, the effect is much less than this and is rarely measurable.

Preconditioning of Film for Phototooling

Recommendation:	Film should be be preconditioned from 4 to 7 hours prior to photo plotting.
Why Precondition:	Preconditioning films for phototooling will improve reliability and consistency of film size holding.
More Control:	Preconditioned film will provide greater control and thus minimize sources of variability as follows: <ul style="list-style-type: none">• Sheet to sheet variation due to differences in length of time film has been exposed to the atmosphere (moisture) prior to plotting.• More predictable post-process size change. Usually faster post-process equilibration time.
Troubleshooting:	Control over this source of variation makes it easier to trouble shoot and identify cause(s) of out-of-control situations.
Practical Steps:	<ol style="list-style-type: none">1. Control temperature and humidity to same conditions in all areas where film is used.2. Precondition film to the operating conditions, for at least 4 hours (90% equilibrium) or to 7 hours (99% equilibrium).3. Standardize the dryer temperature of the film processor. See Table III. These starting point dryer temperatures will be near optimum for achieving a zero process dimension size change. Exact drying temperature must be established empirically.4. Determine post-process equilibration time by measuring at 5-minute intervals until size change stops.
Conditioning Cabinet:	Must be light tight when closed. Filter should be replaced or cleaned on a maintenance-scheduled frequency. Examine interior for dust, using flashlight; clean interior as needed using house vacuum or with clean-room vacuum cleaner. Racks or shelves should be examined carefully for any burrs that could cause scratching.
Conditioning:	Generally, the film must be free to exchange moisture with the air. This is most easily accomplished by placing individual sheets of film on separate shelves in a conditioning cabinet.
Separating Films for Humidity Equilibration:	A stack of film, open to the air, may require hundreds of hours to equilibrate. It may take weeks or months depending on the size and stack of film. There is no practical way to condition stacks of film. Methods such as fanning a stack of film, or tricks such as interleaving sheets of film with previously conditioned paper, are contrivances not worthy of endorsing or considering because of the unpredictable outcome.

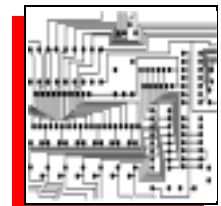

Equation for Calculation of Size Change

Humidity Coefficient: 0.0009 % / % RH

Temperature Coefficient: 0.0018 % / °C

$$\begin{aligned} \text{Size Change} &= \text{Original Size} \times \frac{\text{Humidity Coefficient}}{100} \times \text{Change in \% RH} \\ &+ \text{Original Size} \times \frac{\text{Temperature Coefficient}}{100} \times \text{Change in } ^\circ\text{C} \end{aligned}$$

Example #1

Film Size: 500 mm (millimetres)

Change in % RH: + 4%

Change in °C: - 2°C

$$\begin{aligned} \text{Size Change} &= 500 \text{ mm} \times \frac{0.0009}{100} \times 4 + 500 \text{ mm} \times \frac{0.0018}{100} \times -2 \\ &= 0.018 \text{ mm} + (-0.018 \text{ mm}) \\ &= 0 \text{ (no change)} \end{aligned}$$

Example #2

Film Size: 500 mm (millimetres)

Change in % RH: + 4%

Change in °C: + 2°C

$$\begin{aligned} \text{Size Change} &= 500 \text{ mm} \times \frac{0.0009}{100} \times 4 + 500 \text{ mm} \times \frac{0.0018}{100} \times 2 \\ &= 0.018 \text{ mm} + 0.018 \text{ mm} \\ &= 0.036 \text{ mm} \end{aligned}$$

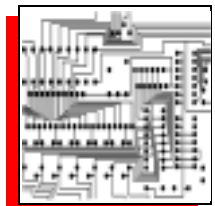

Dimensional Change Characteristics for Printed Circuit Board Films

Summary—Pearls of Wisdom

Pearl	Wisdom
Film Base	Know the limits of 7-mil polyester film. All polyester films have humidity coefficient of 0.0008 %/ % RH "Will film base meet the required tolerance?" Understand the rheology of the material.
Environment Control	Humidity and temperature control are a Must!
Precondition Film	Condition and plot film at the same humidity and temperature to be used in resist imaging. Sheets must be conditioned separately. Expose both sides to moving air. Stacked sheets will take weeks to equilibrate.
Drying Conditions and Size Change	Process Dimensional Change (PDC). Determine dryer temperature for Zero PDC. —Under dry is under size. —Over dry is over size.
Equilibration	Equilibrate film to new conditions before measuring.
Time to Equilibrate	Humidity: emulsion equilibrates rapidly. Temperature: emulsion equilibrates rapidly. Humidity: PET base takes 1 hour per mil thickness. Temperature: PET base equilibrates rapidly.
Film Storage	Store film flat. Do not roll film.
Reversible Changes	Size changes due to changes in relative humidity and temperature are considered reversible, except above 60°C (140°F) (leads to permanent change).
Four Causes of Size Change	(1) Relative humidity (2) Temperature (3) Processing (4) Aging (> 3 years fairly negligible)
Emulsion Gel Layers	Exert compressive forces on the base with absorption and desorption of moisture.
Polyester Base	Expands and contracts with absorption and desorption of moisture.
X + Y Axialism Dimensions	Changes in dimension should be within 10% of each other in X-Y dimensions.
Post Process Equilibration	1/ 4 hour is adequate if film was preconditioned to same environment before exposing and processing.

NOTICE: The sensitometric curves and data in this publication represent product tested under the conditions of exposure and processing specified. They are representative of production coatings, and therefore do not apply directly to a particular box or roll of photographic material. They do not represent standards or specifications that must be met by Eastman Kodak Company. The company reserves the right to change and improve product characteristics at any time.

Industrial Imaging
EASTMAN KODAK COMPANY • ROCHESTER, NY 14650

