

KODAK ACCUMAX Photoplotter Film RED7

—High Complexity PCB Starts With the Right Phototools—

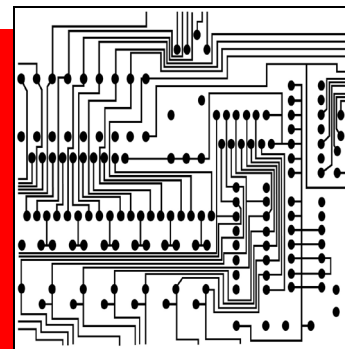

May 2005 • TI-2585

Creating high-complexity phototools starts with the right film. Now from Kodak, you get a hard, line-edge quality and good dimensional stability with KODAK ACCUMAX Photoplotter Film RED7. RED7 Film uses the latest Integrated-Booster-Technology (IBT processing)—technology pioneered by Kodak. Some of its outstanding features include:

- Extremely sharp line-edge quality, with the latest in Integrated Booster Technology processing, recommended for processing in IBT compatible developers such as KODAK ACCUMAX Rapid Access Developer and Replenisher.
- Suitable for lines and spaces as small as 1 mil and photoplotter resolution settings as high as 12,000 DPI.
- Rapid processing, as fast as 30 seconds development time, for high productivity.
- Matte is on the emulsion side, to provide rapid draw-down to photoresist.
- Excellent resistance to photoabrasion and physical wear.
- Permanent anti-static performance to resist the attraction of dust and dirt.
- Dual red sensitivity at 633 nm and 670 nm for use with photoplotters using helium-neon (HN) or red-laser-diode (RLD) exposing sources.
- Very good line reproduction on photoresist.

RED7 Film is designed for use with the following photoplotters:

Manufacture*	Model
Mania Barco	BG-3800, BG-3900, BG-7300, BG-7400, BG-7500, SilverWriter
Dainippon Screen	RG 4000, RG 7000, RG 7500
First EIE SA	RG 24, RP 300, RP500
Escher-Grad	EG-5000, EG-8200, EG-9000, EG-9400
Mania Barco (Gerber)	Crescent 30, Crescent 40
Glaser	Galaxy 3000, Galaxy 4000, Galaxy 6000
Lavenir	PULSAR 8000SE
Orbotech	LP 7008
Secma International	Swift 2028, Swift 2636, Swift 3242, Swift 4257, Swift 4763

*Products are trademarks of the respective manufacturer.

SUPPORT

Dimensionally stable support:

7-mil (0.18 mm)	ESTAR Thick Base
-----------------	------------------



DARKROOM RECOMMENDATIONS

Darkrooms can be illuminated using an **EncapSulite T20/ND0.75 "cyan"** filter.

The light should be at least 1.2 metres (4 feet) from any area where the film will be handled. Where possible, the safelights should be located as to maximize room lighting for safety but minimize direct exposure to the film surface itself. The farther away the lights are located from the film, the greater the margin of safety. This filter should provide *up to 2 minutes* of acceptable safelight performance, under the stated conditions.

European Office:

EncapSulite International Ltd.
Frau Karia Hoppe,
EncapSulite Sales
Postfach 900-3285
Köln 90 Germany

US Address:

EncapSulite
International Inc.
505 Julie Rivers Road
#170
Sugar Land, TX
77478-2848

STORAGE AND HANDLING

Keep unexposed film and processed film in a cool, dry place. Process film as soon as possible after exposure.

EXPOSURE

The exposure required is a function of both the photoplottter characteristics and development conditions. Optimum exposure must be determined by means of a trial exposure series following the equipment manufacturer's recommended procedures. The calibration test will determine optimum exposure for the required line width and D-max. The resulting image quality and D-max can be influenced by variations in time and temperature of development. Some customers may find that a small change to the recommended time and temperature will provide improved results for their particular exposing conditions.

Exposure Conversion Factors

When converting from another film, the following exposure factors can be used as a starting point. Multiply your current laser intensity setting by the factors as a starting point. An exposure sweep of over and under exposure is strongly recommended to determine optimum laser intensity. Please note the factors assume processing in the recommended developer and processing conditions as specified by the manufacturer.

Converting to RED7 from:	LD Exposure Multiplier	HN Exposure Multiplier
ARD7	X0.8 TO 0.5	X0.8 TO 0.5
IPR7 / HPR7	X0.8 TO 0.5	X0.8 TO 0.5
VR7 / IMR7	X0.8 TO 0.5	X0.8 TO 0.5

Note: For Gerber Crescent 30 and 40 models, use a neutral density filter of 1.9 to 2.0 ND.

RECIPROCITY

With recommended processing, the reciprocity speed change is negligible ($\frac{1}{3}$ -photographic stop or less) within exposure range of 1/1000 second to 1 billionth second; there is no change in contrast.

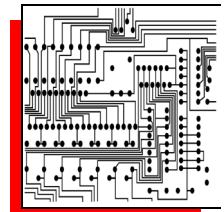

PROCESSING

Notice: Observe precautionary information on product labels and on the Material Safety Data Sheets.

Product	Size	Dilution	CAT No.
KODAK ACCUMAX Rapid Access Developer and Replenisher	5 L concentrate	1:2 with H ₂ O	887 5569
KODAK Rapid Fixer and Replenisher	5 L concentrate	1:3 with H ₂ O	174 9837

Recommended Starting Points

Developer Temperature	Time (seconds)
ACCUMAX Developer	
32°C (90°F)	30 to 45*

* For Gerger Crescent, and EIE plotters, use a starting point developer time of 45 seconds. For Braco, DS and Orbotech plotters use a starting point development time of 30 seconds.

Fixer: Use a fixer temperature of 32 - 35°C (90 - 95°F).

Replenishment Rates

Developer*	Fixer†
350 mL / sq m	540 mL / sq m

* Anti-oxidation replenishment should be set to achieve one tank turnover per week.

† As a starting point, do not add hardener to the fixer. If abrasion or transport problems occur in processing, a small amount of KODAK Rapid Fixer, Part B can be added. Start with 1 oz. of Part B per working strength gallon of fixer, and increase as necessary to a maximum of 3.2 oz. per gallon. Follow the instructions for adding Part B—slowly and mixing thoroughly.

Recommendations at Setup:

- ✓ Confirm processing time and temperature with calibrated stopwatch and digital thermometer. Adjust control settings to achieve the desired set points
- ✓ Measure replenishment rates with a graduated cylinder or beaker. Adjust replenishment settings to deliver required volume of developer and fixer for sheet size being used.

DIMENSIONAL STABILITY

Dimensional stability is an all-inclusive term. In photography, it applies to size changes caused by changes in humidity and in temperature, and by processing and aging. The dimensional properties of ESTAR Base may vary slightly in different directions within a sheet. The differences that may exist, however, are not always equal in both the length and width directions.

Differences in size changes between length and width should be within 10 percent of each other.

Thermal Coefficient of Linear Expansion

Unprocessed or processed	0.0018% per degree C (0.0010% per degree F)
--------------------------	--

Humidity Coefficient of Linear Expansion

Unprocessed	0.0015% per % RH
Processed	0.0014% per % RH

Processing Dimensional Change

Depending on actual drying conditions.

Recommended dryer temperature starting point	43°C (110°F)
--	--------------

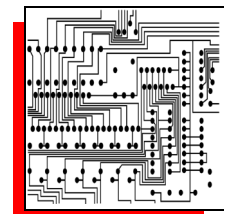

KODAK ACCUMAX Photoplotter Film RED7

CURVES

Characteristic Curves

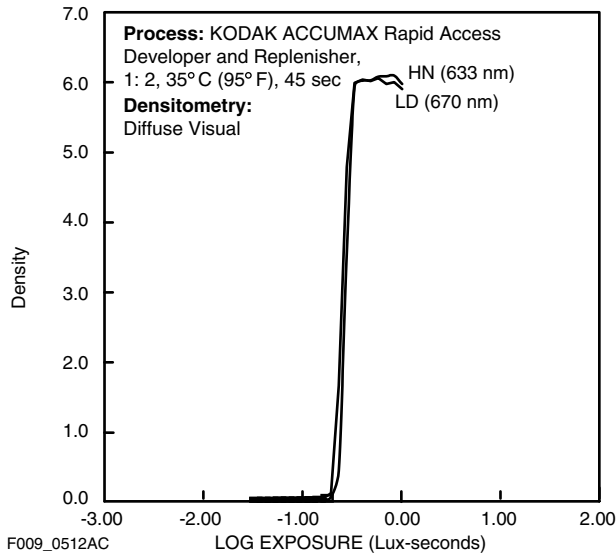

Spectral Sensitivity Curve

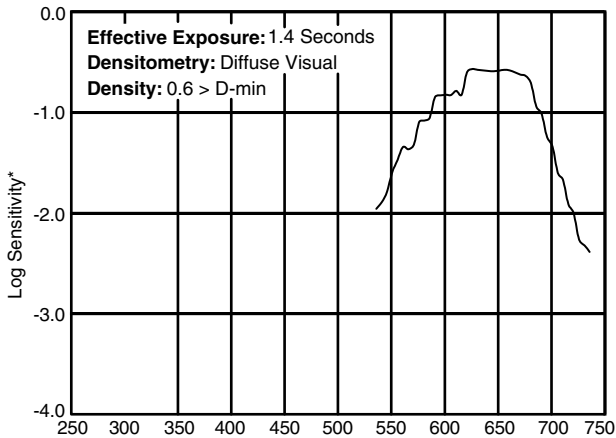

*Sensitivity = reciprocal of exposure (erg/cm²) required to produce specified density

F009_0513AC

MORE INFORMATION

For the latest version of technical support publications for Kodak products, visit Kodak on-line at:
<http://www.kodak.com/go/PCBproducts>

If you have questions about Kodak products, call Kodak.

In the U.S.A.:

1-800-242-2424, Ext. 19, Monday–Friday
9 a.m.–7 p.m. (Eastern time)

In Canada:

1-800-465-6325, Monday–Friday
8 a.m.–5 p.m. (Eastern time)

From outside the US/Canada: 1-716-724-4000

Note: The Kodak materials described in this publication for use with RED7 Film are available from dealers who supply Kodak products. You can use other materials, but you may not obtain similar results.

NOTICE: The sensitometric curves and data in this publication represent product tested under the conditions of exposure and processing specified. They are representative of production coatings, and therefore do not apply directly to a particular box or roll of photographic material. They do not represent standards or specifications that must be met by Eastman Kodak Company. The company reserves the right to change and improve product characteristics at any time.

Aerial and Industrial Markets Business
EASTMAN KODAK COMPANY • ROCHESTER, NY 14650

