

KODAK ACCUMAX Photoplotter Film AGX7

—High Complexity PCB Starts With the Right Phototools—

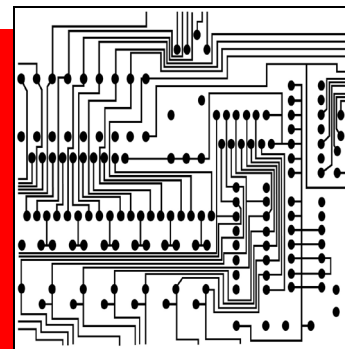

May 2005 • TI-2298

Set new standards for phototool production with KODAK ACCUMAX Photoplotter Film AGX7. This advanced film delivers superb image quality and line sharpness with raster imaging photoplotters that use blue-green laser light sources.

- Extremely high contrast, blue/green sensitive film.
- Designed to produce high quality phototools on raster imaging photoplotters, and other artwork generators with output at 488, 532, 543, and 565 nanometres.
- Dimensionally stable emulsion.
- Excellent scratch and abrasion resistant overcoat.
- Coated on a dimensionally stable ESTAR Base with antistatic and surface properties to ensure dependable transport and handling behavior. This property also helps to resist attraction of dirt and dust.
- Excellent line-edge acuity for critical phototools.
- Contains ultra-fine matte on the emulsion side to improve handling and vacuum draw-down to photo resist.
- Excellent reciprocity characteristics for dependable photoplotting performance.
- Can be handled under light red (series 1A) safelight.
- Recommended for processing in KODAK ACCUMAX Rapid Access Developer and Replenisher.
- CANNOT be processed in lith or KODAK ULTRALINE Developer and Replenisher.

AGX7 Film is designed for use with the following photoplotters:

Manufacturer	Model
Heidelberg	MW 800, MW 1550
CSI	Fire 9000
Dainippon Screen	RG 6500
EIE	8000
Excellon	LPG 2001
Mania Barco (Gerber)	Flat Bed 28
Lavenir	RPG Series, Pulsar 8000
Mivatec GmbH	Miva 1450, 16xx, 25xx, Turbo
Optronics	2000
Orbotech	5008, 5008 XP
Pentax	LPP-3677, LPP-3800

SUPPORT

Dimensionally stable support.

7-mil (0.18 mm)	ESTAR Thick Base
-----------------	------------------

DARKROOM RECOMMENDATIONS

Use a KODAK 1A Safelight Filter / light red in a suitable safelight lamp equipped with a 15-watt bulb. Keep the film at least 1.2 metres (4 feet) from the safelight.

STORAGE AND HANDLING

Keep unexposed film and processed film in a cool, dry place. Process film as soon as possible after exposure.



EXPOSURE

The exposure required is a function of both the photoplotter characteristics and development conditions. Optimum exposure must be determined by means of a trial exposure series following the equipment manufacturer's recommended procedures. The calibration test will determine optimum exposure for required line width and D-max. The resulting image quality and D-max can be influenced by variations in time and temperature of development. Many customers may find that a change to the recommended time and temperature will provide a more suitable result for their particular exposing conditions.

RECIPROCITY

With recommended processing, the reciprocity speed change is negligible within exposure range of 1/1000 second to 100 seconds there is no change in contrast.

PROCESSING

Notice: Observe precautionary information on product labels and on the Material Safety Data Sheets.

	Size	CAT No.	Dilution
KODAK ACCUMAX Rapid Access Developer and Replenisher	5 L concentrate	887 5569	1:2 with water
KODAK Rapid Fixer and Replenisher	5 L concentrate	174 9837	1:3 with water

Recommended Starting Points

Developer Temperature	Time
ACCUMAX Rapid Access Developer	
35°C (95°F)*	45 seconds*
38°C (100°F)	30 seconds
32°C (90°F)	60 seconds

*Optimum starting point recommendation for ACCUMAX Developer.

Fixer: Use a fixer temperature of 32 - 35°C (90 - 95°F).

Replenishment Rates:

Developer*	Fixer†
350 mL / sq m	540 mL / sq m

* Anti-oxidation replenishment rates should be set to achieve one tank turnover per week.

† As a starting point, do not add hardener to the fixer. If abrasion or transport problems occur in processing, a small amount of KODAK Rapid Fixer, Part B can be added (CAT No. 173 3013, 72-ounce bottle). Start with 8 mL of Part B per litre of well mixed, working strength fixer, and increase as necessary to a maximum of 25 mL per litre. Add Part B slowly and mix thoroughly.

Recommendations at Setup:

- ✓ Confirm processing time and temperature with calibrated stopwatch and digital thermometer. Adjust control settings to achieve the desired set points
- ✓ Measure replenishment rates with a graduated cylinder or beaker. Adjust replenishment settings to deliver required volume of developer and fixer for sheet size being used.

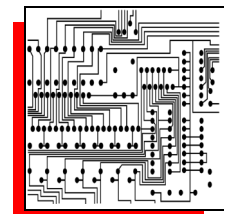

DIMENSIONAL STABILITY

Dimensional stability is an all-inclusive term. In photography, it applies to size changes caused by changes in humidity and in temperature, and by processing and aging. The dimensional properties of ESTAR Base may vary slightly in different directions within a sheet; the differences that may exist, however, are not always equal in both the length and width directions.

Differences in size change between length and width directions should be within 10 percent of each other.

Thermal Coefficient of Linear Expansion

Unprocessed or processed	0.0018 % per degree C 0.001 % per degree F
--------------------------	---

Humidity Coefficient of Linear Expansion

Unprocessed	0.0013 % per % RH
Processed	0.0012 % per % RH

Processing Dimensional Change

Processing Dimensional Change	Dependent on drying conditions
-------------------------------	--------------------------------

CURVES

Spectral Sensitivity Curve

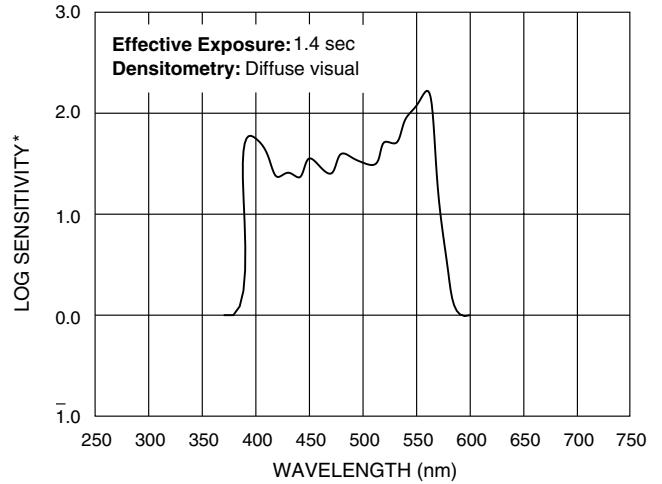

*Sensitivity = reciprocal of exposure (erg/cm²) required to produce specified density

F009_0411AC

Characteristic Curve

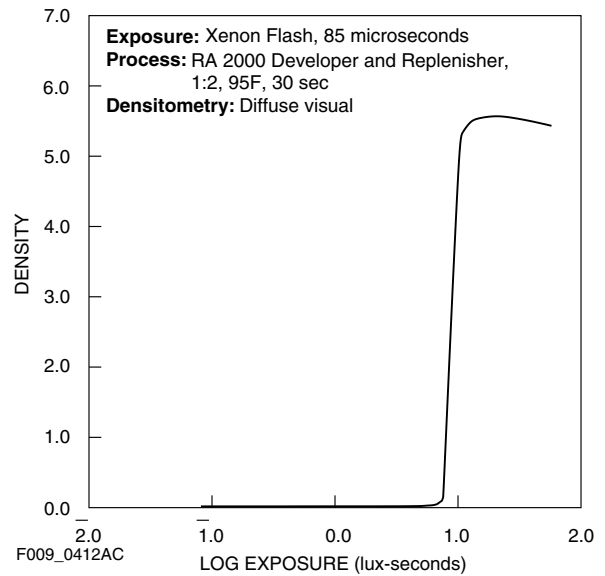

F009_0412AC

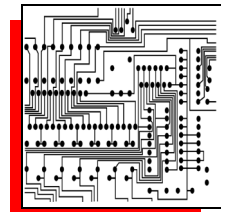

KODAK ACCUMAX Photoplotter Film AGX7

MORE INFORMATION

For the latest version of technical support publications for Kodak products, visit Kodak on-line at:
<http://www.kodak.com/go/PCBproducts>

If you have questions about Kodak products, call Kodak.

In the U.S.A.:

1-800-242-2424, Ext. 19, Monday–Friday

9 a.m.–7 p.m. (Eastern time)

In Canada:

1-800-465-6325, Monday–Friday

8 a.m.–5 p.m. (Eastern time)

From outside the US/Canada: 1-585-724-4000

Note: The Kodak materials described in this publication for use with AGX7 Film are available from dealers who supply KODAK PROFESSIONAL Products. You can use other materials, but you may not obtain similar results.

NOTICE: The sensitometric curves and data in this publication represent product tested under the conditions of exposure and processing specified. They are representative of production coatings, and therefore do not apply directly to a particular box or roll of photographic material. They do not represent standards or specifications that must be met by Eastman Kodak Company. The company reserves the right to change and improve product characteristics at any time.

Aerial and Industrial Markets Business
EASTMAN KODAK COMPANY • ROCHESTER, NY 14650

